

1

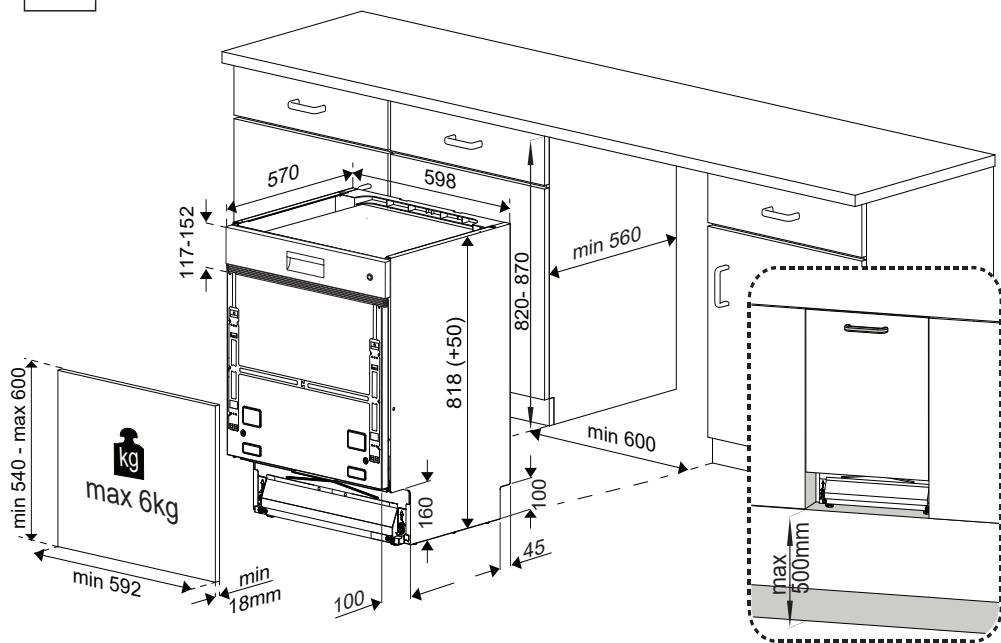

2

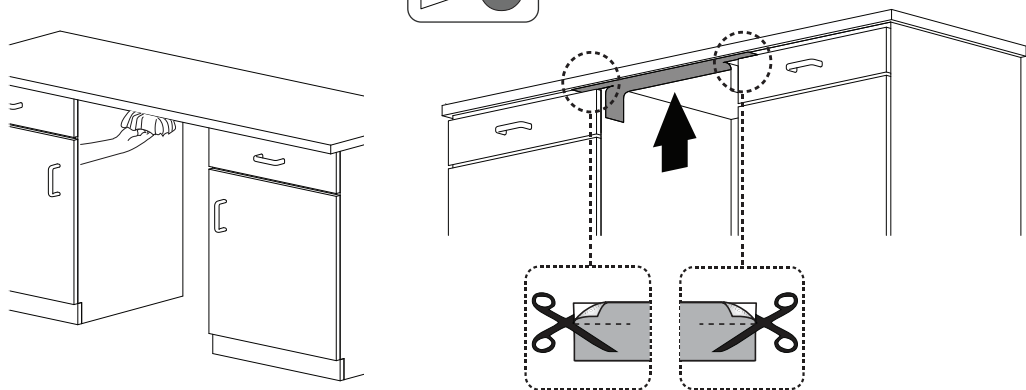
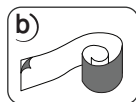

3

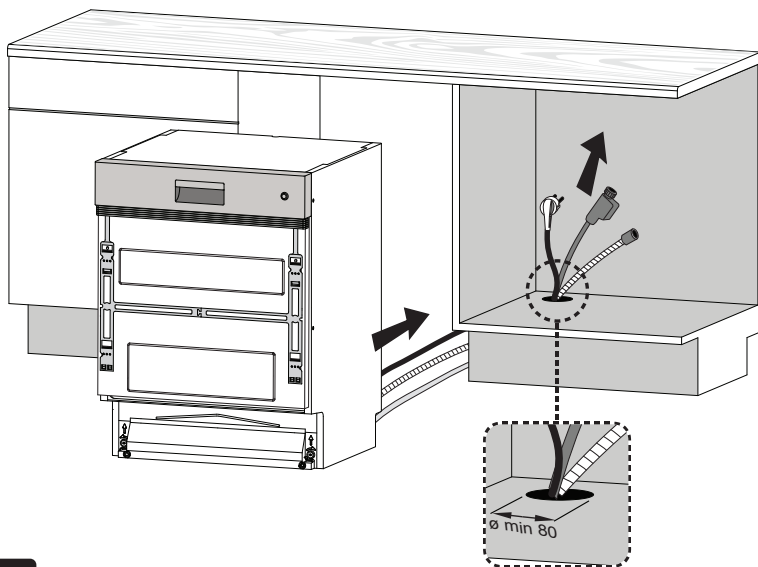

4

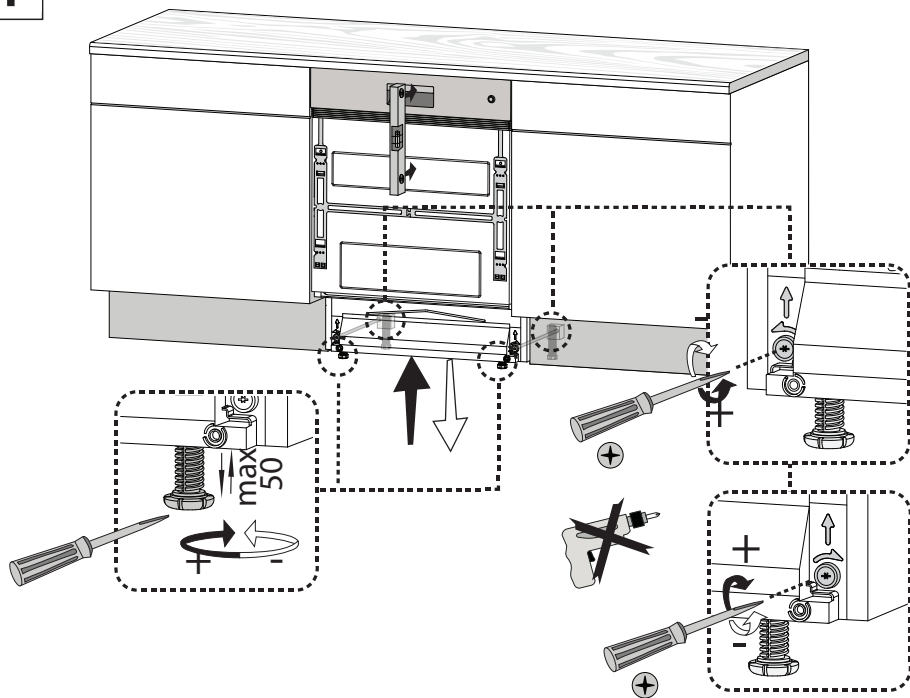

5

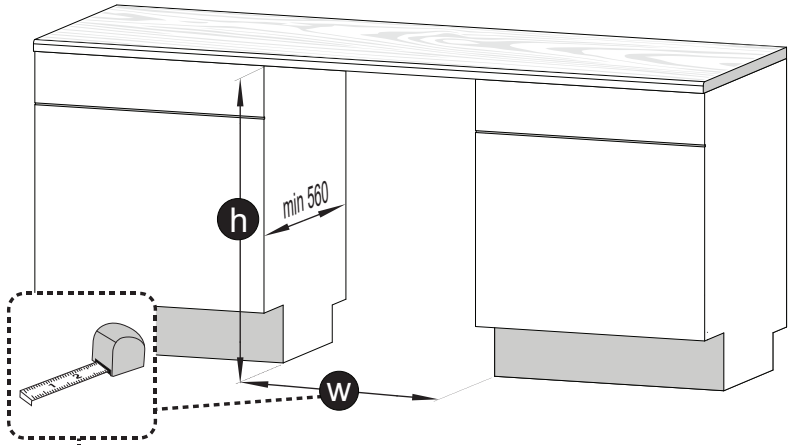

$w > 610$   
↓  
6

$w = 600 - 610$   
↓  
8

6

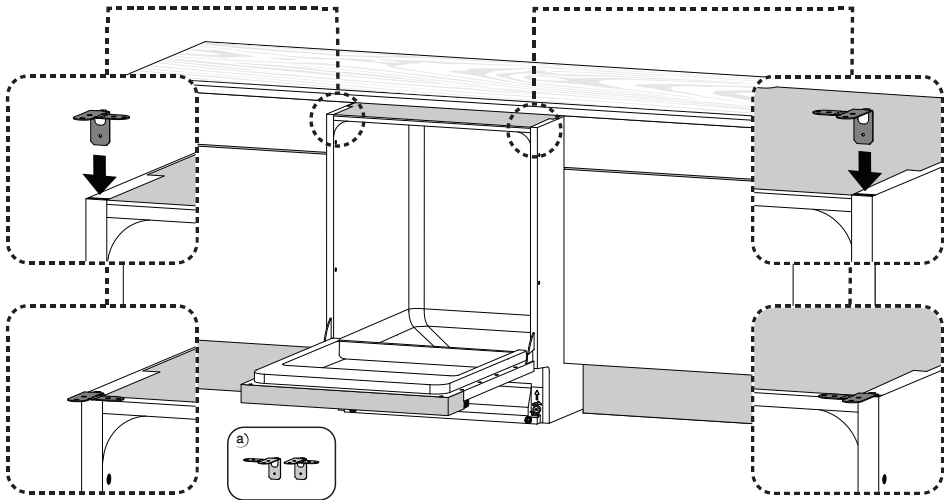

7

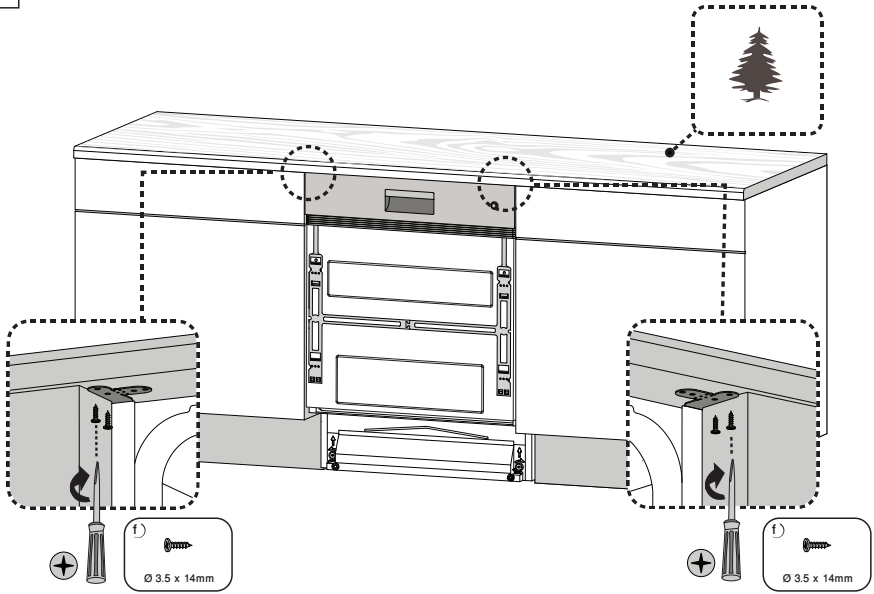

9

8

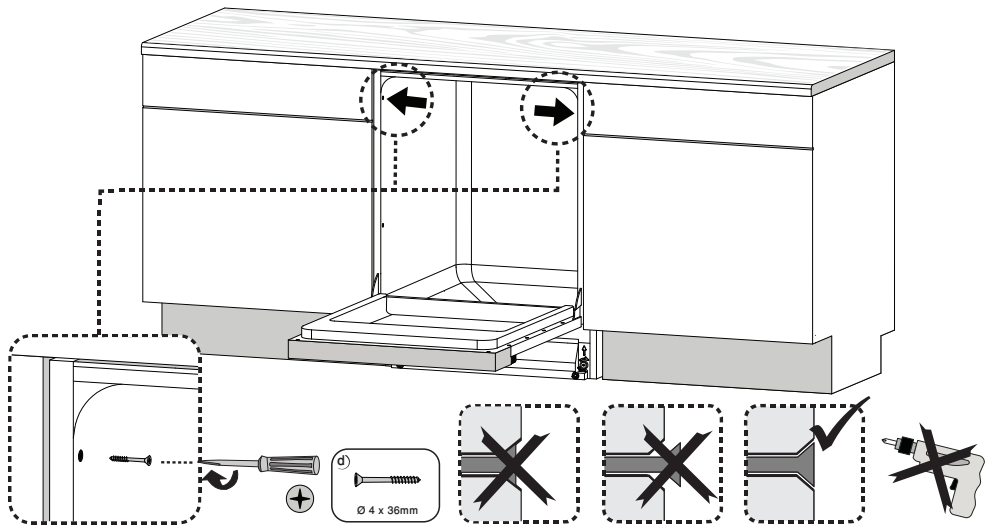

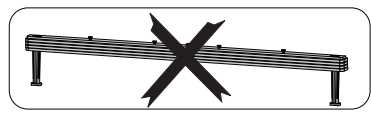
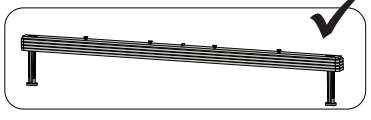

9

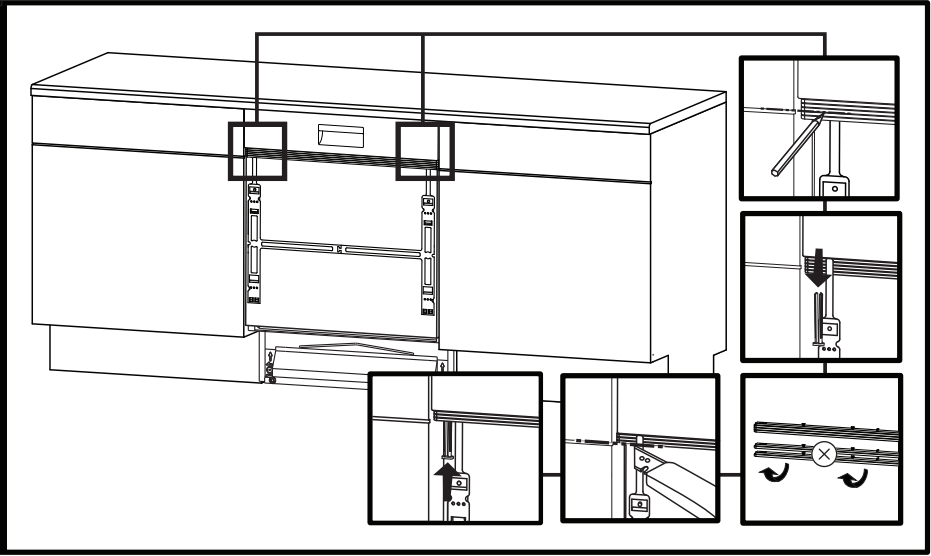

10

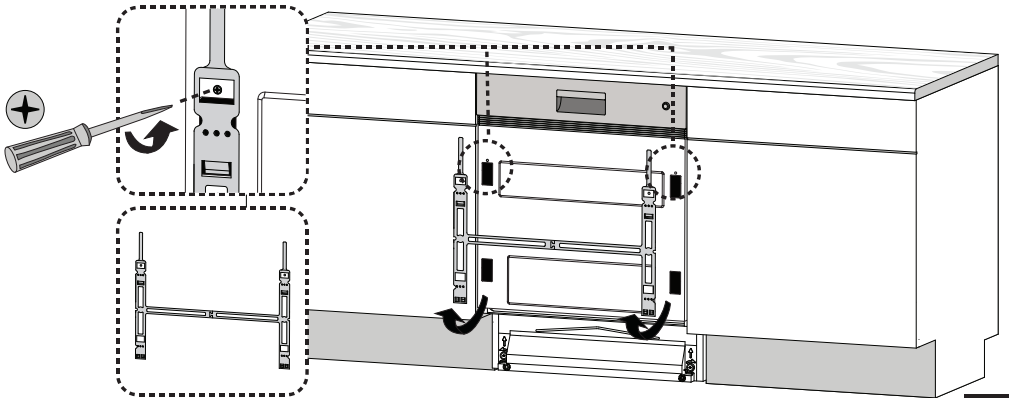

# 11

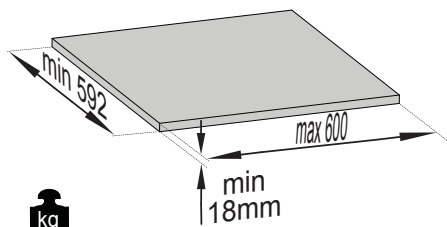

kg  
Max 6kg

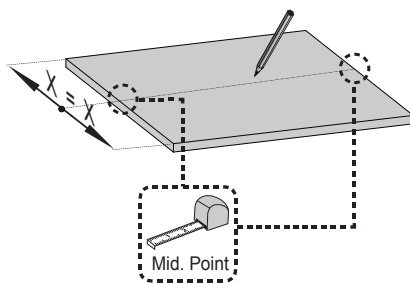

# 12

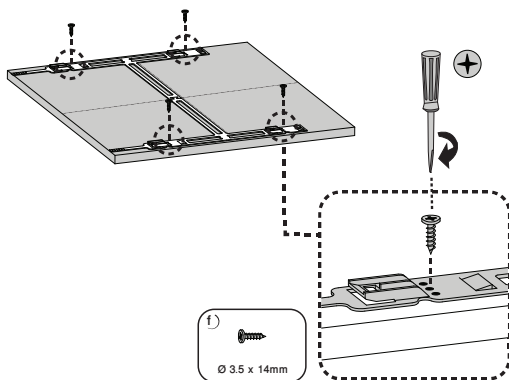
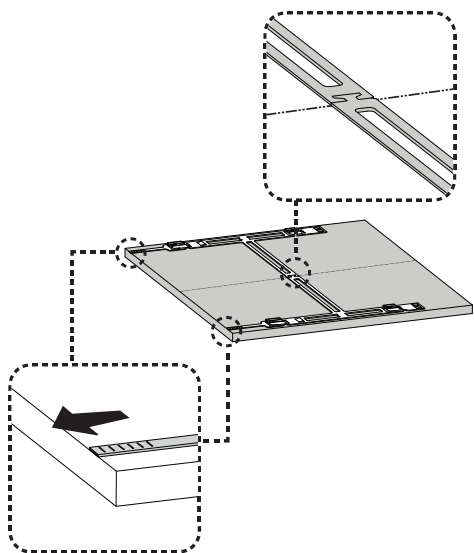



13

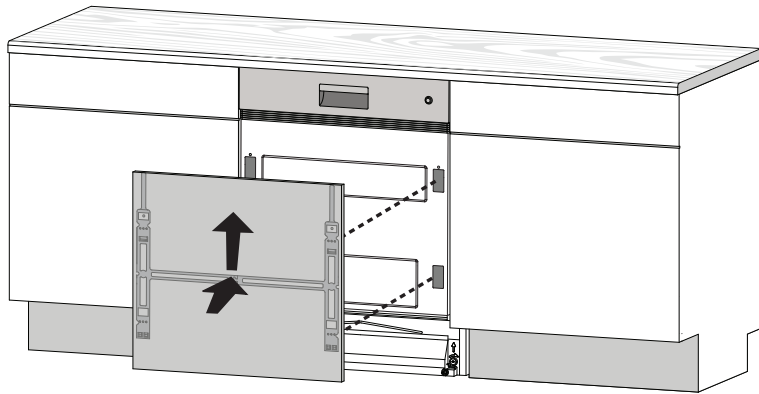

14

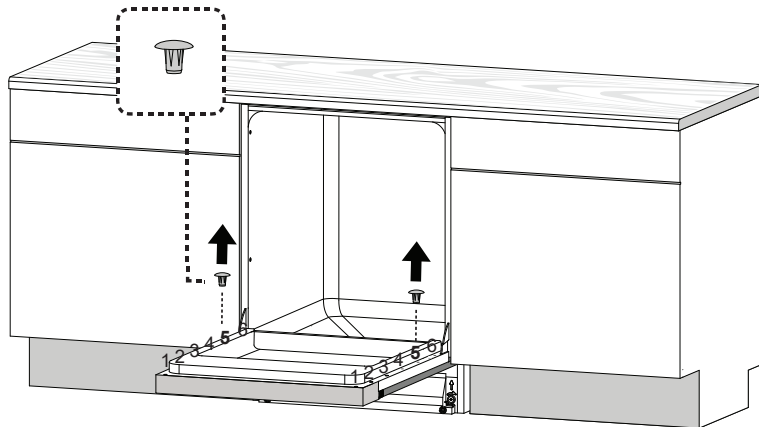

15

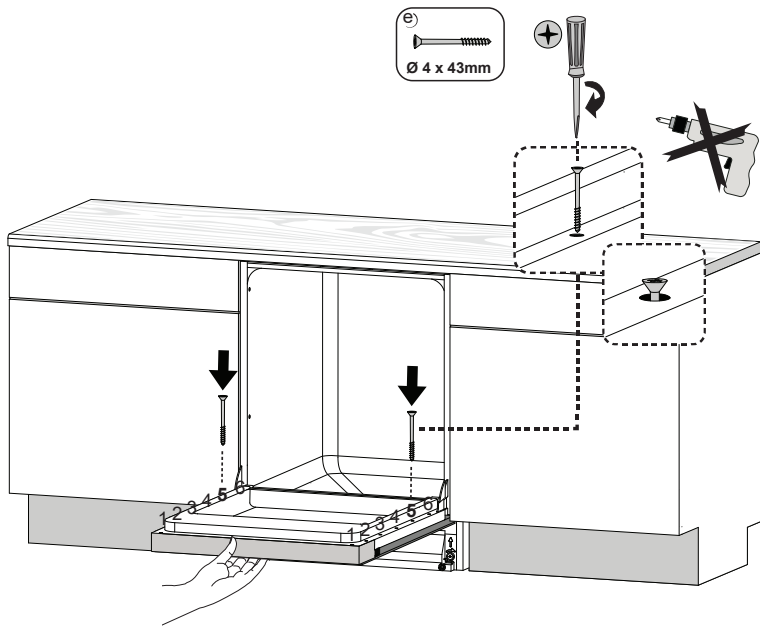

16

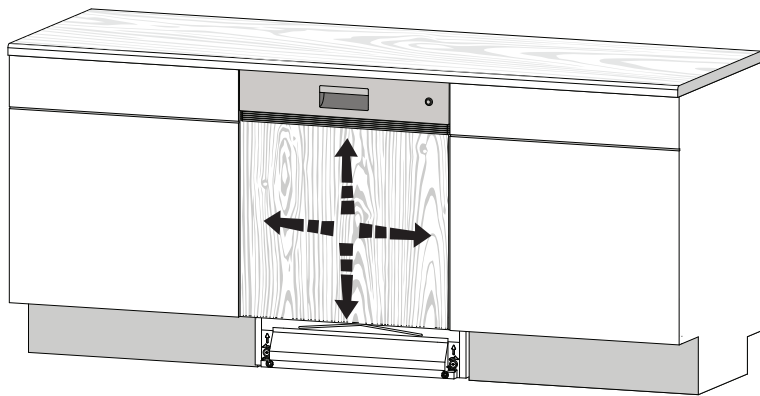

17

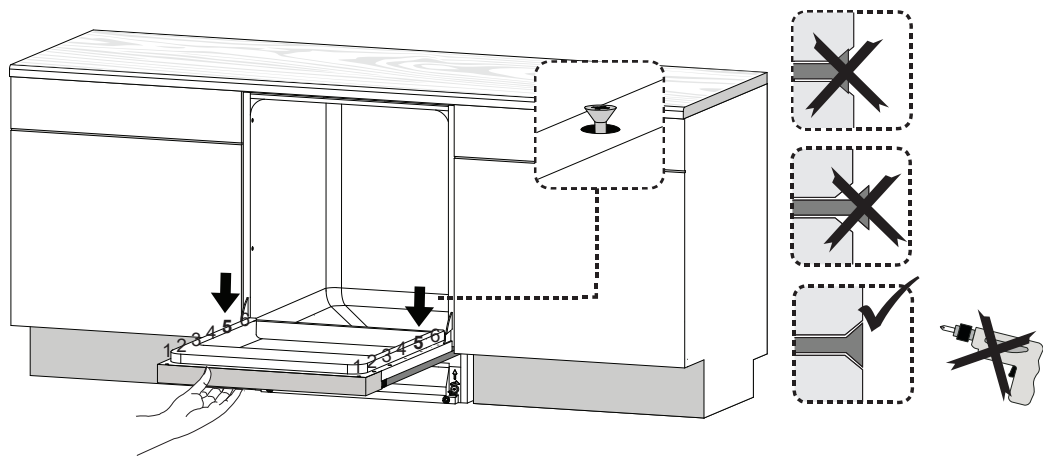

18

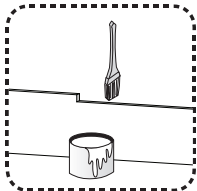
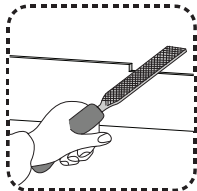
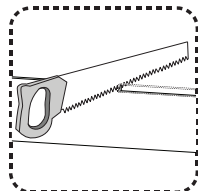
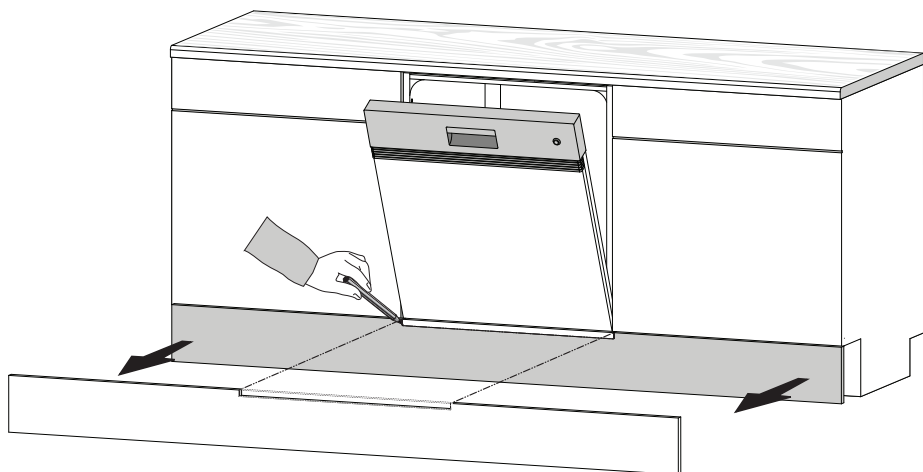

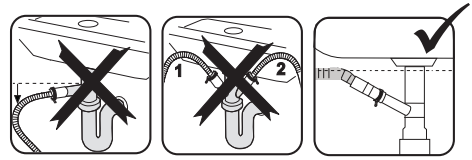
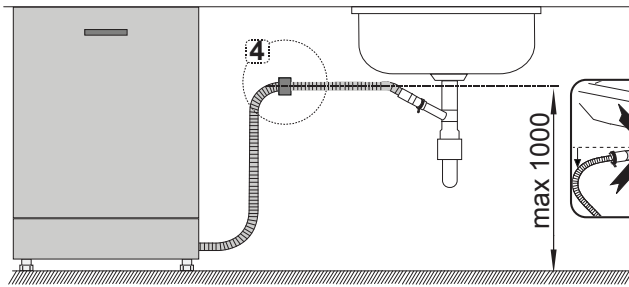
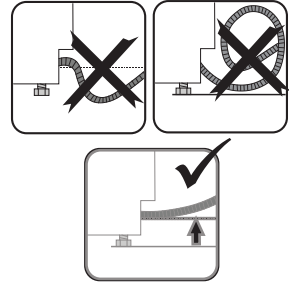
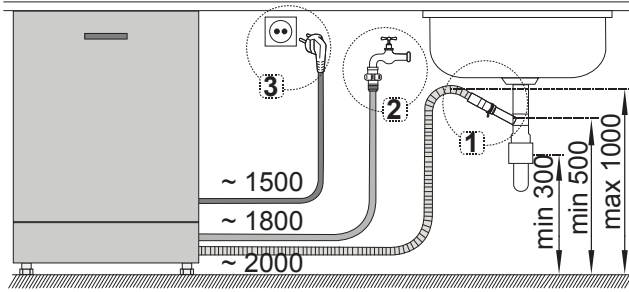

**1**

**2**

**3**

**4**



